

Homework Assignment I

Reading Assignment: Lecture Notes; Kerns-Irwin Chapter 2, Section 2-1 to Section 2-6.

1. Consider the voltage-divider circuit shown below with $v_S(t) = 60 \cos(120\pi t)V$, $R_1 = 2\Omega$, and $R_2 = 4\Omega$.

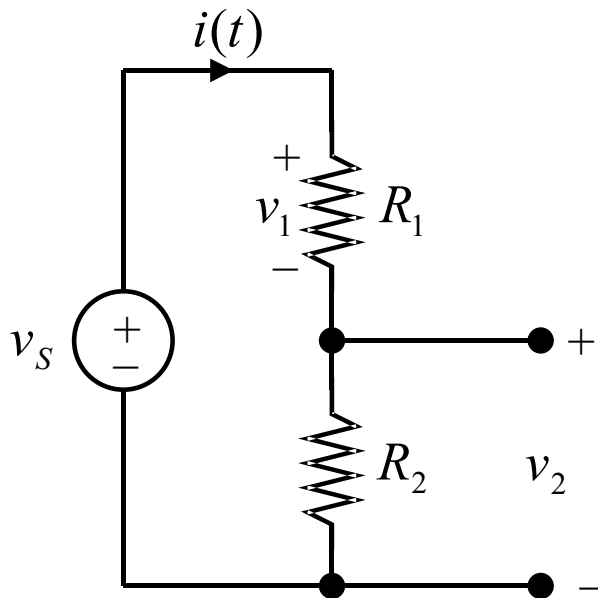

Figure 1: A voltage-divider circuit.

- Find the most compact expression of $v_2(t)$ as a function of time.
- Sketch $v_S(t)$, $v_1(t)$, and $v_2(t)$. Do they make sense? Label your plots carefully.
- For $v_2(t)$, compute: the peak voltage, the RMS voltage, the period in seconds, and the frequency in Hz.
- Compute: the peak and RMS value for the main current $i(t)$.
- Compute the power dissipated in R_2 and sketch it to scale versus time.
- If we take a wire and connect the two terminals of v_2 , what would be the current running through that wire?
- Find the voltage $v_2(t)$ after we take out the short-circuit wire between the 2 terminals above and insert a 4Ω resistor between the two terminals instead.

2. Consider the simple circuit with the AC voltage source with a peak value of V_S depicted below. Your answers in this problem should be expressed as functions of V_S and R .

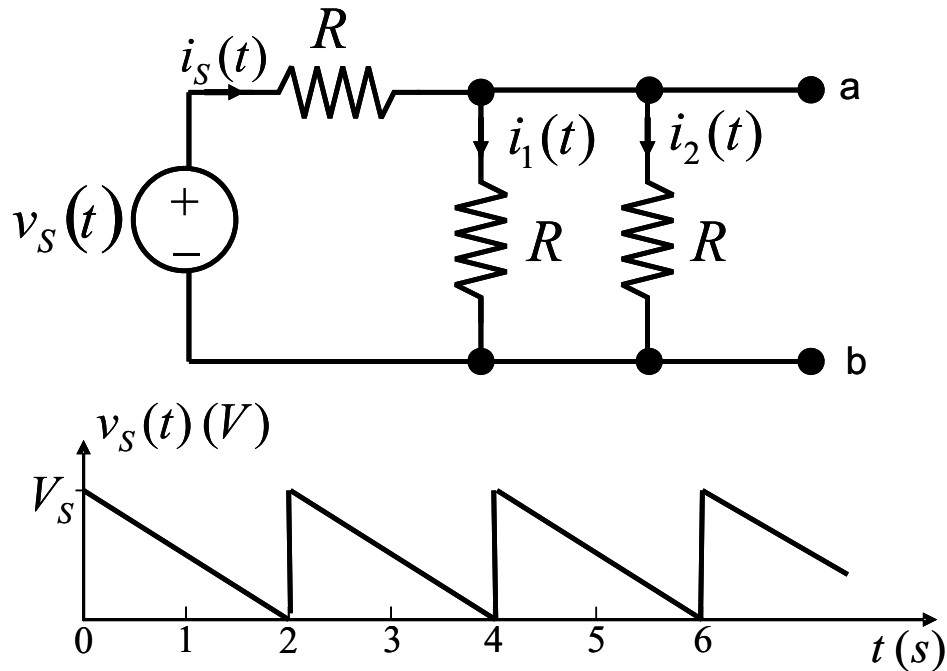

Figure 2: A current-divider circuit.

- Find $i_S(t)$, $i_1(t)$ and $i_2(t)$ and sketch them as functions of time.
- Find the voltage between the 2 terminals a and b (we can label it $v_{ab}(t)$) and sketch it as a function of time. What about $v_{ba}(t)$?
- Find the period, frequency, peak current $I_{PEAK-TO-PEAK}$, average current I_{AVE} , and root-mean-squared current I_{RMS} for $i_S(t)$.
- Find an expression for the instantaneous power $p_2(t)$ dissipated in the right-most resistor R . Sketch it as a function of time.
- Which of the three resistors dissipates the most power in the RMS sense? Explain.
- How much energy does the voltage source $v_S(t)$ have to produce to power the entire circuit over a duration of one minute?

Due date: **September 15** in class