

Homework Assignment II

Reading Assignment: Lecture Notes; Kerns-Irwin Chapter 3.

1. Consider the resistive circuit in a diamond topology on the left of the figure below. This is commonly known as the *Wheatstone Bridge*, often used in electrical measurement applications. Note that this circuit can be redrawn as shown on the right side.

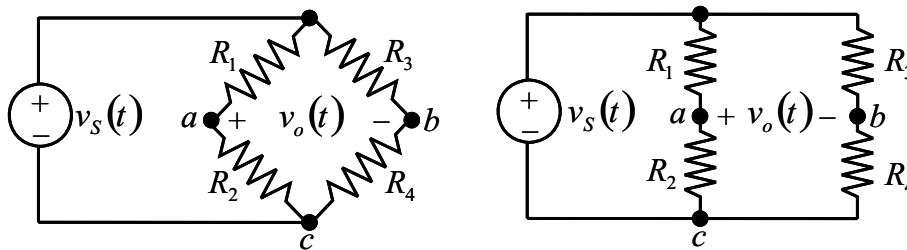

- (a) Find $v_{ac}(t)$ – the voltage across the resistor R_2 – and $v_{bc}(t)$ – the voltage across the resistor R_4 – as a function of the source voltage $v_S(t)$.
- (b) Find $v_O(t)$ – the voltage across nodes a and b – as a function of the source voltage $v_S(t)$ given that $R_1 = R_4$ and $R_2 = R_3 = 2R_1$. *Hint:* $v_{ab}(t) = v_{ac}(t) - v_{bc}(t)$.
- (c) If the source voltage is $v_S(t) = 9 \cos(4\pi t)$, find the period, frequency, average voltage V_{AVE} , and root-mean-squared voltage V_{RMS} for $v_O(t)$.
- (d) Sketch the instantaneous power $p_S(t)$ generated by the voltage source given the same set-up as in Part **b** and **c**.
- (e) If the stock room only carries 1Ω resistors, design and sketch your resulting Wheatstone Bridge where $v_O(t)$ is always precisely $\frac{1}{6}v_S(t)$.
- (f) Suppose that the source voltage is $v_S(t) = 9 \cos(4\pi t)$ and all 4 resistors are 1Ω . Find the Thevenin equivalent circuit looking into the 2 terminals a and b .
- (g) Find the Norton equivalent circuit looking into the 2 terminals a and b .

2. The circuits below models the voltage produced by the generator of a power plant and R_S models the resistive losses in the generator, wire, and transformers. Resistances R_1 , R_2 , and R_3 represent the various loads connected by a customer. Assume that $R_1 = R_2 = R_3 = R_S = R$.

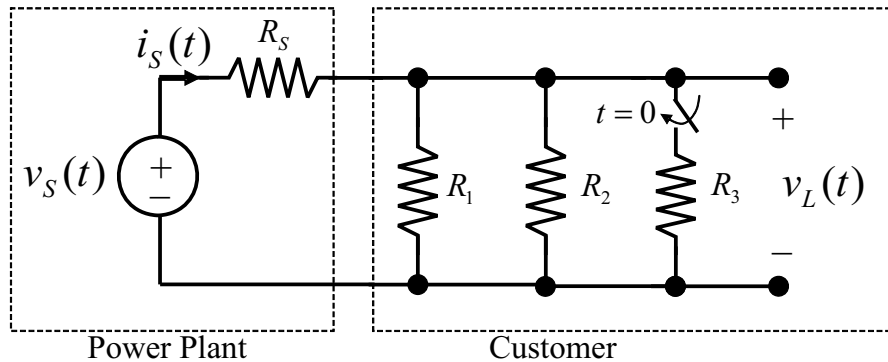

- Find the load voltage $v_L(t)$ as a function of the source voltage $v_S(t)$ for $t < 0$ (before the customer closes the switch and connects the third load).
- Find the load voltage $v_L(t)$ as a function of the source voltage $v_S(t)$ for $t > 0$ (after the customer closes the switch and connects the third load).
- Sketch the load voltage $v_L(t)$ and the source current $i_S(t)$ as functions of time assuming that $v_S(t)$ is a DC source with peak value of $150V$.
- Sketch the source current $i_S(t)$ as a function of time assuming that $v_S(t)$ is a $60Hz$ AC source with RMS value of $170V$.
- For the AC source above, how much energy does the voltage source at the power plant produce over one source period (cycle) before and after the switch is closed?

Due date: **September 26** in class